

SCREENER

KOMPATTO 104

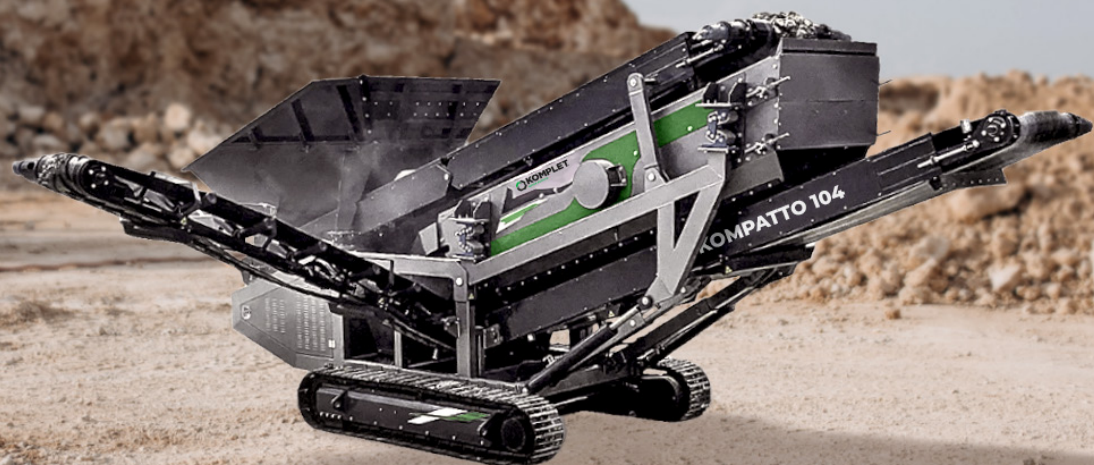

1. 3,015x1,240 mm
8x4 inch
2. 3,015x1,240 mm
8x4 inch



- | | |
|----------|--------------|
| Stage V | 35 kW |
| | 45 Hp Diesel |
| Tier 4F | 35 kW |
| | 45 Hp Diesel |
| Stage 3A | 36 kW |
| | 47 Hp Diesel |



Up to 200 tph
220 US tph



8,000 kg
17,636 lb

WORKING

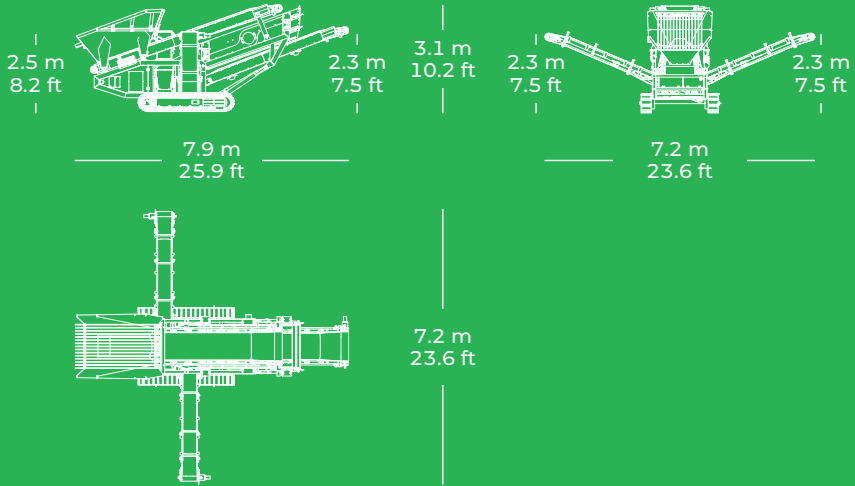

FEATURES AND BENEFITS

- High capacity up to 200 tph / 220 US tph (depending on feed size, mesh & material type).
- Quick set-up.
- Hydraulically folding conveyors.
- Fit into a 40ft container.
- Smart design minimised weight 8 ton.
- Variable speed feeder.
- Removable grid for screenig before crusher.
- Designed for a wide range of materials and aggregates.



Komplet S.p.a.

Via Antonelli, 49 60012 Trecastelli (AN) Italy

✉ info@komplet.it

☎ +39 071 6609823

VAT IT02035890421

